

SET-UP INSTRUCTIONS

for K&M microphone stands

Design: solo stand - folding feet - extendable stand tubes - with boom arm



KÖNIG & MEYER

Stands For Music

MODEL

21020, 21021, 21030, 21040, 21045, 21060, 21070, 21075, 21076, 21079, 21080, 21090, 25200, 25205, 25210, 25400, 25500, 25600, 25900, 25905, 25907, 25910, 25935, 25950, 25970, 25975, 25976, 25977, 25979, 27105, 27140, 27195, 27700, 27740, 27800

FEATURES

Versatile microphone stand complete with boom arm.
High-quality workmanship, stability, flexibility, and durability.
As a compact package, it is ideal for touring.

Example model designation: 21090-300-55

21090 = Model no. (short number)

-300 = Code for 3/8"-BSW thread

-500 = Code for 5/8"-UNS-27G thread

-02 = chrome-plated surfaces

-55 = black surfaces (powder-coated)

-87 = basalt gray surfaces (powder-coated)

Base: Bell-shaped base (zinc or PA) with three folding feet

Stand: Base tube and extension tube

- or base tube, extension tube, and end tube

Infinitely variable locking of the height using:

- Clamping sleeve

- or clamp with knurled screw

- or one-hand clutch

Threaded bolt (BSW-3/8", UNS-5/8"-27G) for:

- Microphone / boom arm / gooseneck

Boom arm: One-piece or extendable

Infinitely variable adjustment and locking of the:

Extension (range) and inclination (+90°/-90°)

With threaded bolt (BSW-3/8", UNS-5/8"-27G)

Material: Base stand and boom arm tubes: steel

Swivel joint: steel/PA

Base, swivel head: die-cast zinc / PA

Thread: steel, galvanized

Grips, bushings: PA

Parquet protector: TPE

Load capacity: max. 1 kg, microphones only

SAFETY INSTRUCTIONS

The stability of the stand depends largely on:

a. **LOAD CAPACITY:** only microphones up to 1 kg

b. **SURFACE:** must be level and load-bearing

c. **EXTERNAL ENVIRONMENT:** protect from wind and unwanted tampering

d. **ADJUSTMENT** of a boom arm: via one of the legs

- The possibility of folding or moving the product naturally involves a risk of entrapment; careful and attentive handling during assembly, operation, and disassembly is therefore essential.

- Occasionally tighten the thread (tighten firmly but do not overtighten).

- For cleaning, use a slightly damp cloth and a non-abrasive cleaning agent.

- Parquet protectors are free of plasticizers as far as possible:
To protect particularly sensitive floors, a non-slip carpet pad should be used if necessary.

INSTRUCTIONS

BASE

- Open feet **1**,

- Loosen base screw **2**,

- Pull out base tube **3** as far as it will go,

- Re-tighten base screw **2**.

STAND

- Slightly loosen the clamping sleeve/knurled screws **4**,

or press together the one-hand clutch

- Bring the extension tube **5** to the desired height

- Release the one-hand clutch, or

re-tighten the clamping sleeve/knurled screws **4**

(DO NOT OVERTURN - hand tight is completely sufficient)

BOOM ARM

- Screw the swivel arm (swivel head, **6**) onto the extension tube of the stand

- Lock position with knurled washer **7** if necessary (see position **12**)

INCLINATION - Loosen clamping nut **7**

- Move boom arm **8** to the desired position

- Re-tighten clamping nut **7**

EXTENSION - Loosen knurled screw(s) **9**

- Extend or retract boom arm **10**

- Re-tighten knurled screw(s) **9**

DIRECTION - Turn the swivel arm **11** in the desired direction

(the clamping sleeve **4** does not need to be loosened)

MICROPHONE

- The connection thread **12** is available in two versions:

- 3/8"-BSW (with loose lock nut/knurled washer)

- 5/8"-UNS-27G (with integrated stop)

- There are cable clamps **13**, **14** on the boom arm and stand tube

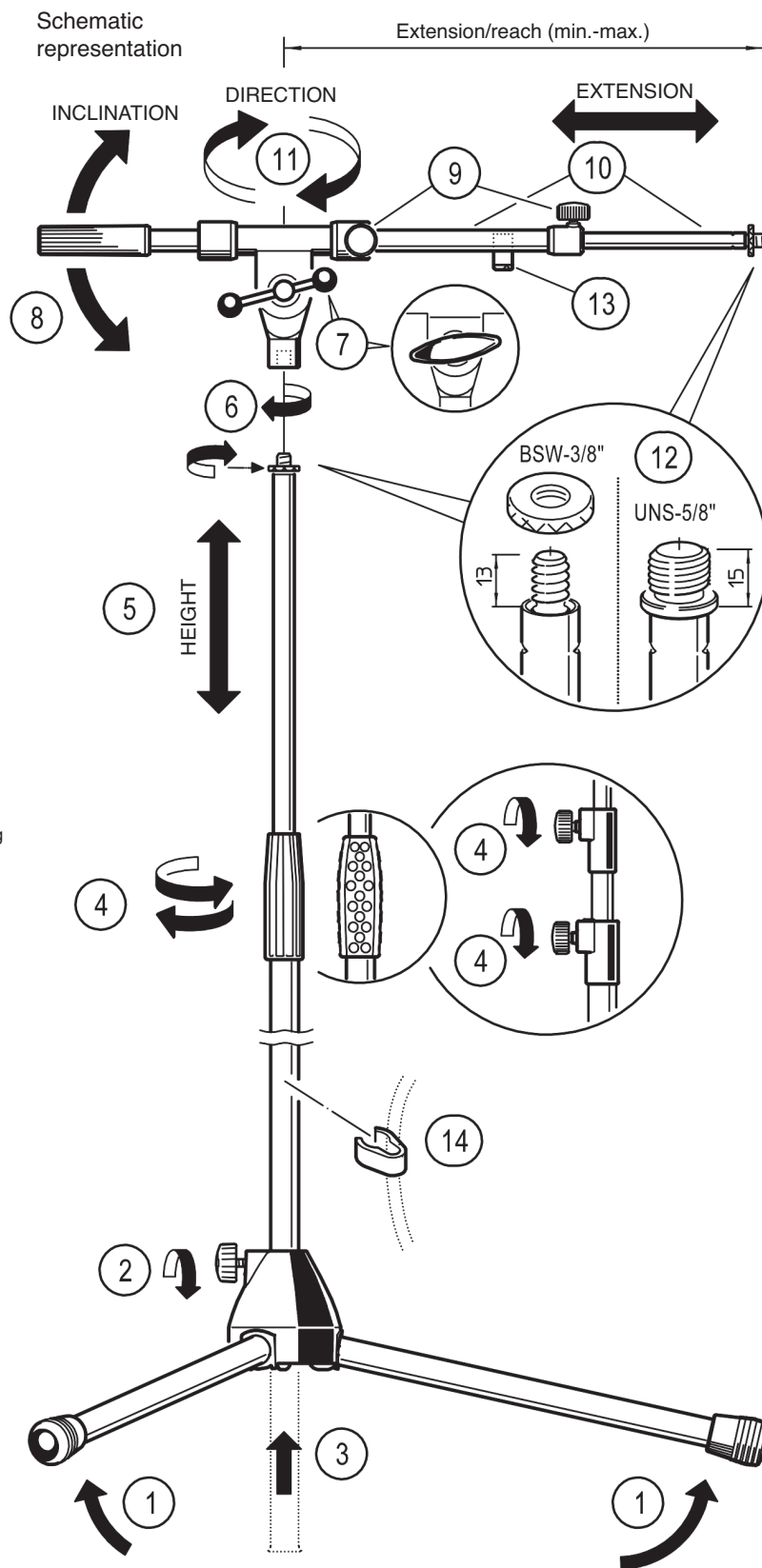

KÖNIG & MEYER GmbH & Co. KG

Kiesweg 2, 97877 Wertheim, Germany

Phone: 09342/8060, Fax: 09342/806-150

E-Mail: contact@k-m.de, Web: www.k-m.de

03-81-002-00 9/24