

# SET-UP INSTRUCTIONS

for K&M microphone stands

Design: solo stand - round base - extendable stand tubes - without boom arm



**KÖNIG & MEYER**

Stands For Music

## MODEL

26000, 26010, 26013, 26022, 26050, 26085, 26125, 26140

## FEATURES

Solo stand with heavy round base;  
the rubber inlay dampens impact sound and protects  
the microphone from unwanted transmission noise.  
Top workmanship, durability, and stability.

Example model designation: 26010-300-55

26010 = Model no. (short number)

-300 = Code for 3/8"-BSW thread

-500 = Code for 5/8"-UNS-27G thread

-02 = chrome-plated surfaces

-55 = black surfaces (powder-coated)

-87 = basalt gray surfaces (powder-coated)

Base: Round cast iron or steel/PA base with rubber inlay

Stand: Base tube and extension tube

Infinitely variable locking of the height using clamping sleeve

Threaded bolt (BSW-3/8", UNS-5/8"-27G) for:

- Microphone / boom arm / gooseneck

Material: Base and extension tube: steel

Base: gray cast iron or steel plate with PA cover  
and rubber inlay

Thread: steel, galvanized

Grips, bushings: PA

Rubber inlay: TPE

Load capacity: max. 1 kg, microphones only

Schematic  
representation

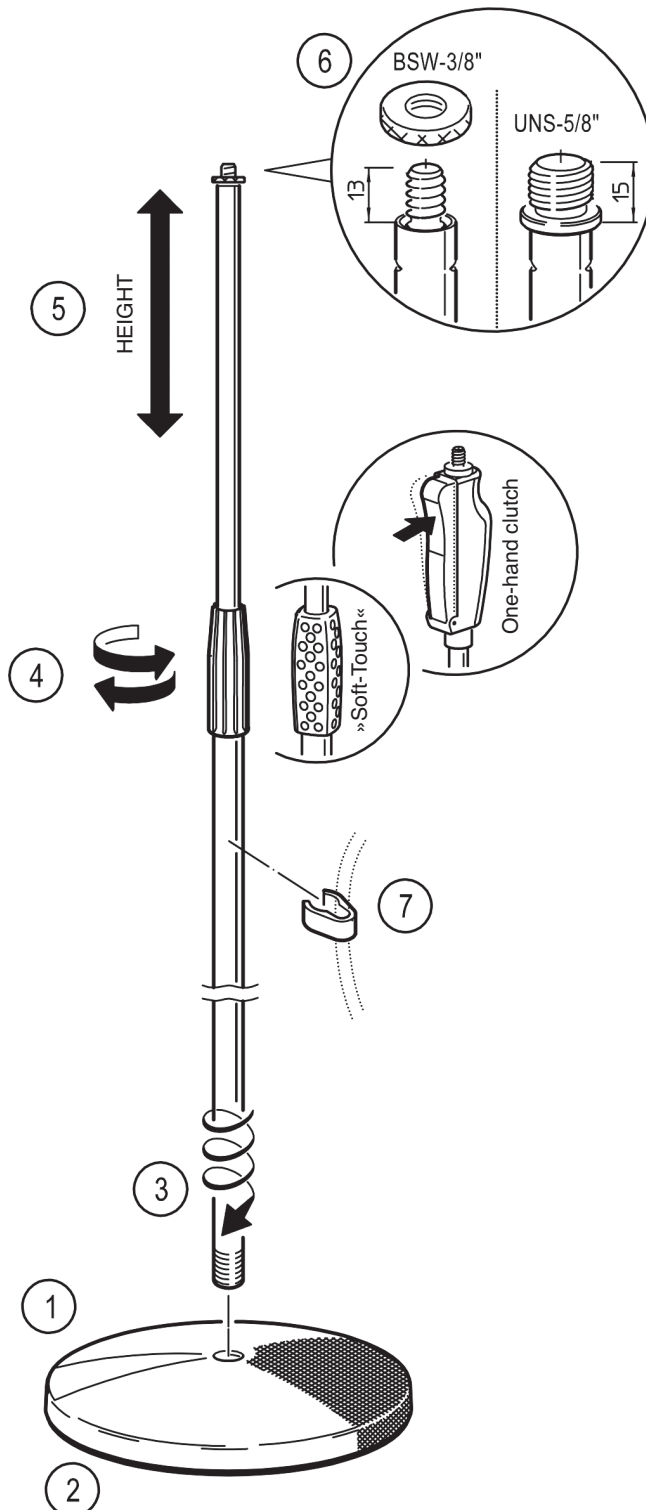

## SAFETY INSTRUCTIONS

The stability of the stand depends largely on:

- LOAD CAPACITY: only microphones up to 1 kg
- SURFACE: must be level and load-bearing
- EXTERNAL ENVIRONMENT: protect from wind and unwanted tampering
- ADJUSTMENT of a boom arm: via one of the legs

- The possibility of folding or moving the product naturally involves a risk of entrapment; careful and attentive handling during assembly, operation, and disassembly is therefore essential.
- Occasionally tighten the thread (tighten firmly but do not overtighten).
- For cleaning, use a slightly damp cloth and a non-abrasive cleaning agent.
- Parquet protectors are free of plasticizers as far as possible: To protect particularly sensitive floors, a non-slip carpet pad should be used if necessary.

## INSTRUCTIONS

### BASE

- Carefully place the round base 1 on the floor ...
- ... with the rubber inlay 2 facing downwards
- Turn base tube 3 into the round base as far as it will go.

### STAND

- Slightly loosen the clamping sleeve/knurled screws 4, or press together the one-hand clutch
- Bring the extension tube 5 to the desired height
- Release the one-hand clutch, or re-tighten the clamping sleeve/knurled screws 4 (DO NOT OVERTURN - hand tight is completely sufficient)

### MICROPHONE

- The connection thread 6 is available in two versions:
  - 3/8"-BSW (with loose lock nut/knurled washer)
  - 5/8"-UNS-27G (with integrated stop)
- There is a cable clamp 7 on the base tube of the stand

KÖNIG & MEYER GmbH & Co. KG

Kiesweg 2, 97877 Wertheim, Germany

Phone : 09342/8060, Fax: 09342/806-150

E-Mail: contact@k-m.de, Web: www.k-m.de

03-81-003-00 9/24