

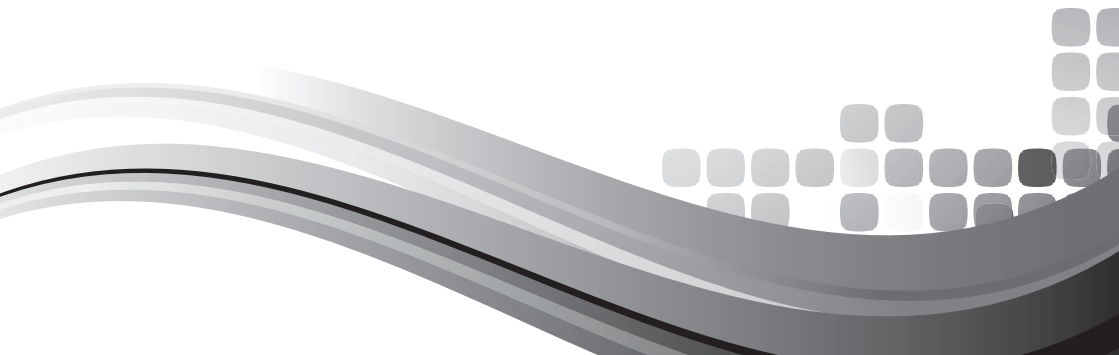

## INSTALLATION AND OPERATION MANUAL

# QF6WRC

WATER RESISTANT CEILING SPEAKER



## IMPORTANT SAFETY INFORMATION

## PRÉCAUTIONS DURANT UTILISATION

1. Read these instructions.
  2. Keep these instructions.
  3. Heed all warnings.
  4. Follow all instructions.
  5. Do not use this apparatus near water.
  6. Clean only with dry cloth.
  7. Do not block any ventilation openings. Install in accordance with the manufacturer's instructions.
  8. Do not install near any heat sources such as radiators, heat registers, stoves, or other apparatus (including amplifiers) that produce heat.
  9. Only use attachments/accessories specified by the manufacturer.
  10. Refer all servicing to qualified service personnel. Servicing is required when the apparatus has been damaged in any way, such as power-supply cord or plug is damaged, liquid has been spilled or objects have fallen into the apparatus, the apparatus has been exposed to rain or moisture, does not operate normally, or has been dropped.
  11. This appliance shall not be exposed to dripping or splashing water and that no object filled with liquid such as vases shall be placed on the apparatus.
1. Lisez ces instructions.
  2. Tenez ces instructions.
  3. Notez tous les avertissements.
  4. Suivez toutes les avertissements.
  5. N'utilisez pas ce produit près de l'eau (la piscine, la plage, le lac, etc.).
  6. Nettoyez seulement avec une étoffe sèche.
  7. Ne bloquez aucuns trous de ventilation. Installez en accord avec les instructions du manufacturier.
  8. N'installez près aucunes sources de chaleur comme radiateurs, registres de chaleur, fours ou les autres équipements (y compris amplificateurs) qui produisent la chaleur.
  9. Seulement utilisez attachements/accessoires spécifiés par le manufacturier.
  10. Référez au personnel qualifié de service pour toutes réparations. La réparation est donnée quand le système a été endommagé à n'importe façon, par exemple un fil ou une fiche endommagé(e) de la source d'alimentation. Avoir été exposé à pluie ou humidité, n'opère pas normalement, ou avoir été tombé.
  11. L'appareil ne doit pas être exposé aux écoulements ou aux éclaboussures et aucun objet ne contenant de liquide, tel qu'un vase, ne doit être placé sur l'objet.
-





## FRONT PANEL

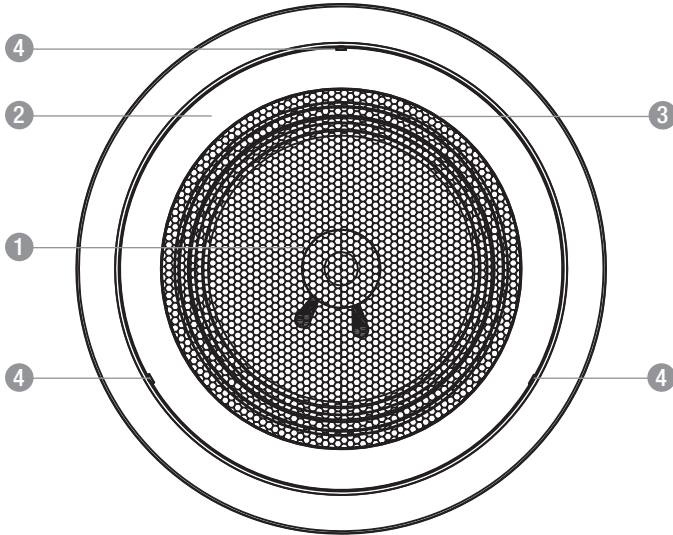

- ① 6" full range driver
- ② Front grille plate
- ③ Grille
- ④ Grille mounting tabs

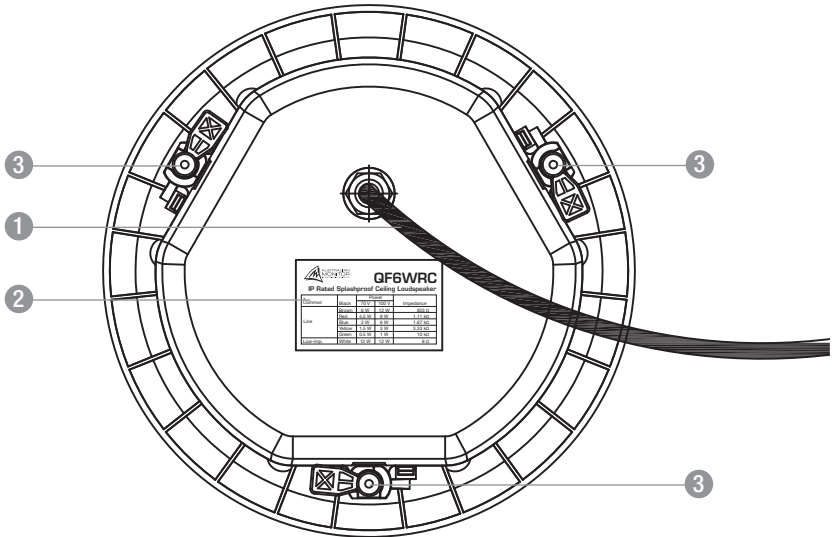

**1 Speaker Input Cable**

Speaker input is via a 7 core cable. Refer to the attached table which identifies the various power tapplings available and also the 8 Ohm direct input.

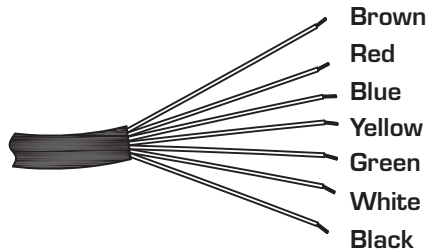

**2 Power Tapping Chart for easy reference**

**3 Mounting tabs (refer to mounting section).**

Tapping	100 V	70 V	Impedance
Brown	12 W	6 W	833 Ω
Red	9 W	4.5 W	1.11 kΩ
Blue	6 W	3 W	1.67 kΩ
Yellow	3 W	1.5 W	3.33 kΩ
Green	1 W	0.5 W	10 kΩ
White	Direct		8 Ω
Black	Common		



## MOUNTING



When mounting QF6WRC speakers the following safety issues must be considered;

The mounting of a permanently installed speaker may be dangerous unless undertaken by a qualified professional with relevant experience.

Ceilings and mounting surfaces must be capable of supporting the speaker in a safe and secure manner.

### Installation

(Refer to page 8 for dimension details)

Cut a hole with a diameter of 209 mm (8.3") in the ceiling ensuring that there is sufficient room both above and at the sides of the hole to comfortably fit the speaker.

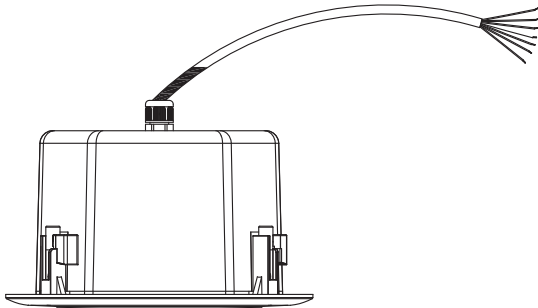

To install the speaker, remove the grille by placing a screwdriver into the three grille release tabs (slots) located around the circumference of the front panel and carefully prying it free. Take care not to scratch the panel with the screwdriver.

Once the grille and front panel have been removed, simply insert the speaker into the ceiling and using a screwdriver, tighten the three mounting tabs located around the circumference of the speaker to lock it into place. Once the speaker is installed, relocate the grille and front plate by securely pressing it back into place.

When wiring the speakers, always connect multiple speaker in parallel and ensure the correct polarity of each speaker, with respect to each other is maintained. Isolate unused wires in the speaker input cable so that they do not contact each other or any other conductive object..

**NOTE** that the QF6WRC has a supervisory capacitor inserted across all 100V tappings.



## Removing the Grille

To remove the grille, simply unclip the front grille plate from the speaker by pressing the grille release tabs which are identified from the front by three small indents located around the circumference of the plate.

If the grille is to be removed whilst the speaker is not mounted, we recommend releasing the tabs from the rear of the speaker so that the front panel is not scratched. If removing from the front, take care not to scratch the front panel.

Once the panel is removed, the grille itself can be removed from the front panel by turning it anticlockwise until the small tabs that hold it in place are released.

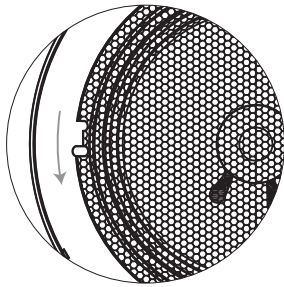

To reassemble, reinsert the grille following the reverse process and the front plate is simply pressed back into the speaker.



## DIMENSIONS

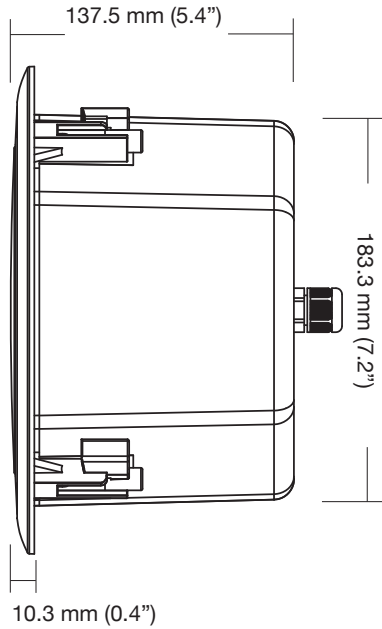
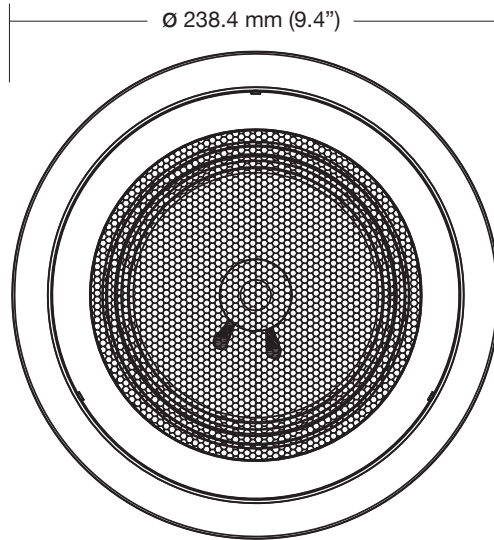





<b>SPECIFICATION</b>	<b>QF6WRC</b>
<b>Impedance (Direct)</b>	8 Ohms
<b>Power (Continuous, Program)</b>	12 W, 24 W
<b>Power Tappings (100 V)</b>	12, 9, 6, 3, 1 Watts
<b>(70 V)</b>	6, 4.5, 3, 1.5, 0.5 Watts
<b>Sensitivity (1 W / 1 M @ 1 kHz)</b>	92 dB
<b>Calculated max SPL (Continuous, Program)</b>	103 dB, 109 dB
<b>Dispersion (1 kHz, 4 kHz)</b>	110°, 65° conical
<b>Frequency Response (-10dB)</b>	150 Hz – 20 kHz
<b>Frequency response (-3 dB)</b>	185 Hz - 19 kHz
<b>Speaker Components</b>	6" Full Range Driver
<b>Ingress Protection</b>	IEC 529 IP 55
<b>Operating Temperature</b>	-30°C ~ +60°C
<b>Net Dimensions (diameter x length)</b>	238.4 x 137.5 mm (9.4" x 5.4")
<b>Net Weight (no carton)</b>	1.7 kg (3.75 lbs)
<b>Shipping Dimensions (W x H x D) (carton)</b>	270 x 270 x 215 mm 10.6" x 10.6" x 8.5"
<b>Shipping Weight (carton)</b>	2.4 kgs (5.3 lbs)



# FREQUENCY RESPONSE

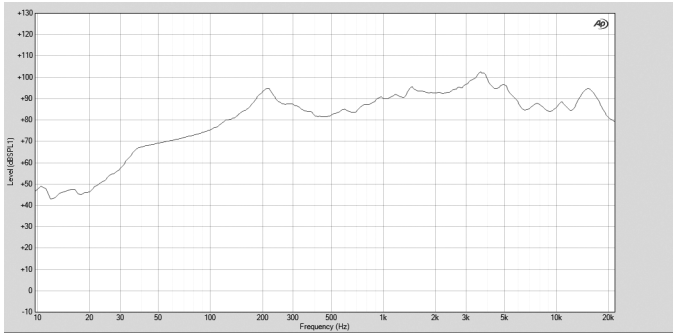





ENGINEERED BY AUSTRALIAN MONITOR

Address: 1 Clyde Street, Silverwater, Sydney NSW 2128 Australia. Private Bag 149, Silverwater NSW 1811 ACN 007 573 417  
Website: [www.australianmonitor.com.au](http://www.australianmonitor.com.au) International enquiries email: [international@australianmonitor.com.au](mailto:international@australianmonitor.com.au)



DISTRIBUTED IN AUSTRALIA AND NEW ZEALAND BY HILLS SVL [www.hillssvl.com.au](http://www.hillssvl.com.au)

NSW	QLD	ACT	WA	VIC	SA	NZ
P: 02 9647 1411	P: 07 3852 1312	P: 02 6260 4544	P: 08 9204 0200	P: 03 9890 7477	P: 08 8408 8300	P: 09 415 9426
E: <a href="mailto:nsw@hillssvl.com.au">nsw@hillssvl.com.au</a>	E: <a href="mailto:qld@hillssvl.com.au">qld@hillssvl.com.au</a>	E: <a href="mailto:act@hillssvl.com.au">act@hillssvl.com.au</a>	E: <a href="mailto:wa@hillssvl.com.au">wa@hillssvl.com.au</a>	E: <a href="mailto:vic@hillssvl.com.au">vic@hillssvl.com.au</a>	E: <a href="mailto:sa@hillssvl.com.au">sa@hillssvl.com.au</a>	E: <a href="mailto:sales@hillssvl.co.nz">sales@hillssvl.co.nz</a>